

Weatherproof Gas Tube Patio Heater

Specification

Power Input: 40,000/80,000/100,000 Btu/h

Length: 128.4"/240.9"/353.5"

Gas Type: NG (3.5"WC) or LP (10.0"WC)

Radiant Tubes:
Heat Treated Aluminized Steel

Certification:
ETL Certified for Commercial/Industrial
Indoor&Outdoor Use

Electrical:
120V/60Hz, 24V Control Module
Amps: 3.7 Starting, 0.5 Running



Features

- Stainless steel hexagonal hole decorative panel for enhanced radiant output
- Two-stage operation
- Pre- and post-purge controls
- Burner viewport for easy monitoring
- Wind resistant up to 12 mph
- 100% efficient reflector
- Heat treated aluminized radiant tube provides increased efficiency and heat output
- Unified control panel with easy access and serviceability
- SUS316L brushed burner box

Keywarm

Weatherproof Gas Tube Patio Heater

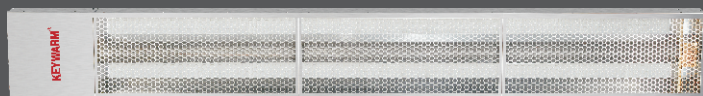

Technical Parameters

MODEL	GAS	BTU/H HIGH FIRE	BTU/H LOW FIRE	LENGTH	WEIGHT	MOUNTING HEIGHTS
LTSO-40	NG (LP)	40,000	28,000	128.4"	74 lbs	8' to 13'
LTSO-80	NG (LP)	80,000	56,000	240.9"	125 lbs	8' to 13'
LTSO-100	NG (LP)	100,000	70,000	353.5"	177 lbs	9' to 14'

Clearance to Combustibles(Dimensions in inches)

MODEL	A	B	C	D	E	F	G	H
LTSO-40	4	45	18	4	38	4	40	13
LTSO-80	4	58	26	4	50	4	58	13
LTSO-100	4	62	28	4	58	4	67	13



0° Mounting Angle

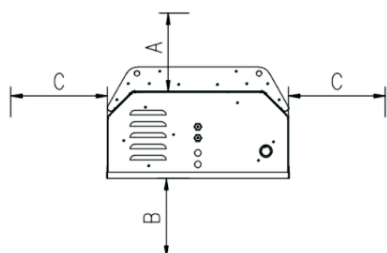

30° Mounting Angle

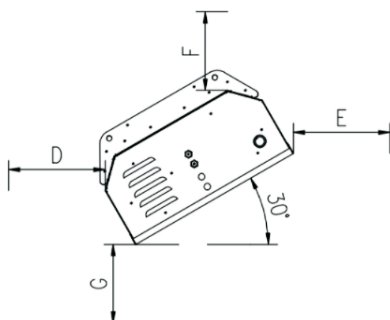

www.patiokeywarm.com
sales@keywarm.com